

# OLCOVO CARDBOARD BOAT REGATTA

**2023**

INFORMATION PACKET



# INTRODUCTION

The Queen's Landing Cardboard Boat Regatta:

- Promotes creativity
- Builds community spirit
- Celebrates community talent
- Deepens relationships
- Increases morale
- Provides laughter, fun and camaraderie
- Provides an activity parents can do with the kids
- Provides an activity that doesn't restrict the fun to household residents only (great activity for grandparents and their grandkids)

Boats are made entirely of cardboard and powered by up to four paddlers. They will race around Macum Creek. Boats compete in individual heats for honor, glory and some pretty cool prizes.

As a part of the QLCOUO fleet and your \$30 registration you will:

- Have a boatload of fun
- Compete in an amazing event
- Receive \$10 voucher to the Food Truck Smorgasbord
- Receive two t-shirts for your team (with the chance to buy additional shirts)
- Receive a burgee for you to decorate and proudly display at your unit while building your boat and on your boat during the race
- Receive a roll of duct tape and a starter pack of cardboard (enough material to build a 2 person boat). Additional cardboard may be available.
- Have a safe racing environment on race day.

# DETAILS

## COMMITMENT

Captains and Crews who wish to participate in the QLCOUO Cardboard Boat Regatta make a commitment to the following:

- Construct a boat out of cardboard and duct tape.
- All boats are human powered (oars and paddles are acceptable as propulsion tools; you provide the oars/paddles; Maximum of 4 people)
- Participate in the entire event which includes:
  - Bringing completed boat to the Macum Creek common area behind Bldg 48 on Saturday, June 3rd by 9 am. (Sunday June 4th as a rain date.)
  - Attending the Captain's Orientation on Saturday, June 3<sup>rd</sup> 9:30 – 10:00 AM
  - Attend the race on Saturday, checking in no later than 11:00 am
  - Stay for awards ceremony after the race
  - Dispose of boat (maintenance dumpster will be available)

## IMPORTANT DATES

### May 23, 2023

Last day for boats to register and pay \$30 registration fee. All boats must have submitted their final Name of Boat (or boat will be only known as the resident's last name). Registration is to be done through [www.SignUpGenius.com](http://www.SignUpGenius.com).

### June 3, 2023 - RACE DAY!

Boats must be brought to the Macum Creek kayak launch by 9:00 A.M. From 9:30 – 10:00 A.M. there will be a Boat Crew and Safety Boat Crew Orientation. All boat crews must come to the Boat Crew Orientation. During this time, we will collect team members' signed waivers and give out t-shirts. Each boat entry will receive a \$10 complementary food voucher for the Food Truck Smorgasbord. From 10:00 am through the start of the race, guests will have the opportunity check out the boat displays in the wharf and "vote" for their favorite boat. This is a great opportunity for boat builders to solicit "votes" for the People's Choice Award. Join us from 1:00 pm to 5:00 pm in the clubhouse parking lot to enjoy music and a variety of foods from some of the best food trucks in the area – Blue Monkey Taco, Spanky's Soul Food and Tasty Toucan.

Boat crews should arrive by 11:00 am. At this time they will be introduced to their race liaison and the Guest Judges will also pick their favorite boat. Teams are encouraged to come earlier if they have a staging area they wish to set up on the common area at their boat. The first boats hit the water at 1 p.m. Awards ceremony begins immediately after the final race.

# AWARDS

## RACE COMPETITION

Boats will randomly draw a heat. The winner of each heat will move on to the final race.

## AWARDS

**First, Second and Third Place Trophies** will be awarded for the top three boats in the final heat. A cardboard boat must complete length of the course to qualify as a “finisher.” Swimming crewmembers pushing a boat (or some portion of it) through the course is not considered “racing.” The boat (or some portion of it) must be maneuvered and propelled by at least one paddling crewmember.

**Cardboard Crusaders Race**- any boat that is still seaworthy (and a “finisher”) and not in the finals is allowed to participate in the Cardboard Crusaders race. This race is a one or two lap race with the winner receiving a special trophy.

Race Awards - Guaranteed to all registered participants including crew members and boat builders. These are handed out during the awards ceremony and each crew is recognized.

Special Trophies will be awarded for the following:

- **Best in Race Award** (1st place) - First boat to cross the finish line in the final heat. Best in Race receives a traveling trophy for one year and will have that trophy replaced at the end of the year with a permanent one they can keep. **Second and Third place trophies** will also be awarded for the final heat.
- **Judge’s Choice Award** - Awarded by the judges based on creativity, showmanship and team spirit. Costumes and props are encouraged!
- **People’s Choice Award** - Awarded to the boat that receives the most votes.
- **Cardboard Crusader Trophy** - goes to the team who wins the Cardboard Crusader heat (see above).
- **The Wonder That Went Down Under Award** (Most Spectacular Sinking) - Awarded to the crew who, in the opinion of the staff, was the most spectacular in the way the ship and its crew went down. (As long as the boat or some part of it is propelled by at least one paddling crewmember, the boat may continue to the finish line.)

Awards Ceremony - will be held after the final heat, after the race and all boats are out of the water and the area is cleaned up.

# CONSTRUCTION AND RACE

- The ENTIRE boat must be built of cardboard, duct tape, and one-part polyurethane. (Any part of your boat that touches the water must be cardboard. This includes the hull, decking, keel, cowling, superstructure, oar locks, seating and rudder. Nuts, bolts, washers and staples are NOT allowed in hull construction. The cardboard may be as thick as you want, but may not be glued or attached to wood, plastic, fiberglass, etc.)
- Only exceptions are the paddles & decorations
- Use cardboard boxes, “blocks”, carpet tubes
- NO pre-treated cardboard allowed
- No Sona-Tubes, waxed or ‘treated’ cardboard
- NO wood, plastic, Styrofoam or fiberglass
- NO caulking compounds or two-part/mixed adhesives
- NO wrapping in duct tape, plastic or fiberglass or similar product
- Duct tape may be used to reinforce seams
- Duct tape, masking tape, or adhesives such as ‘liquid nails’ CAN be used to connect cardboard to cardboard and CAN be used to reinforce all seams and stress points. It CANNOT be used to waterproof boats.
- Waterproof the boat with Varnish, Paint or Polyurethane (one-part, paint-like substance). (If you don’t want your boat to sink, waterproof the entire boat with any paint-able, one-part substance like Varnish or Polyurethane inside and out.)
- Decorations are encouraged as long as they don’t affect structural strength or buoyancy
- Boats CANNOT tow anything behind them for the safety of other boats.



# CONSTRUCTION AND RACE continued

- The crew compartment CANNOT be enclosed so as to interfere with escape
- Every crewmember must wear a PERSONAL FLOATATION DEVICE (PFD) & proper footwear. Please provide your own PFDs.
- All crew members MUST sign a Participant Waiver/Hold Harmless Agreement on race day. Boats will not be allowed to race without a signed agreement from each race participant
- Minimum of ONE crewmember
- All boats are human powered (oars and paddles you provide are acceptable as propulsion tools)
- Alcoholic beverages are NOT permitted for crew members and safety boats during the races
- Boats should weigh less than 200 lbs – This rule is for us. (Please keep your boat under 200 lbs. If you need help getting out of the creek, we need the odds stacked in our favor.)
- Boats should be less than 6 feet wide – Here more is not better
- Care should be taken that construction does not include pointed objects and sharp edges that could injure anyone
- Surfboard style designs are NOT allowed. Consider “staying dry” part of the challenge.
- Raft style designs ARE allowed. (The distinguishing feature of a raft design as opposed to a surfboard style is the use of cardboard “logs” and other such accoutrements as one would expect to find in/on a raft. Think Huck Finn.)

# CONSTRUCTION AND RACE continued

**RACE DAY** - Please check in (entire crew) at the registration table on race day no later than 11:00 am. (Boats arrive by 9 am). Unload your boat in the display area. You may drive your vehicle to the end of Queen Anne Way to unload your boat, however, after unloading, please move your vehicle to the overflow parking areas or back to your building parking. Set up your boat display. After the safety inspection is complete, Boats will race other boats around the buoy set up in Macum Creek. There will be safety boats with tubes in the water to pick up sinking crew if necessary. All crew are to wear Coast Guard approved PFDs. After the race, the boat crews must remove all cardboard, decorations and other materials from the water and the grounds. Volunteers will be on hand to help.

You can take your boat home with you or dispose of it in on-site recycling bins.

If there is any doubt about the construction, the judges reserve the right to use a probe, such as an ice pick, to test and verify that only cardboard has been used. Failure to abide by any design, race rule or the direction of a race official shall be cause for disqualification. The Judges' decision shall be final.

Please contact Bob Karnei at [bobk@queenslanding.org](mailto:bobk@queenslanding.org) if you have any questions.

# CONSTRUCTION MATERIALS

<b>Permissible Materials</b>	<b>Materials NOT Allowed</b>
Corrugated Cardboard (found at appliance or grocery stores)	Wood
Cardboard “blocks” (found at furniture stores)	Styrofoam, Pool Noodles, Great Stuff type foam, inflatable plastics
Cardboard Tubes (found at carpet/flooring stores)	Plastic Sheathing, Tarps, Vinyl Sheeting
Duct or Masking Tape	Fiberglass
Liquid Nails Adhesive	Sona-Tubes (coated cardboard)
Latex Paint/Varnish	Silicone/Wax/Tar
	Caulking Compounds
	Metal
	Staples/Clamps/Screws
	Plastic Supports, tubing, containers or jugs

Judges decide on the interpretation of the rules.



# CONSTRUCTION MATERIALS EXAMPLES

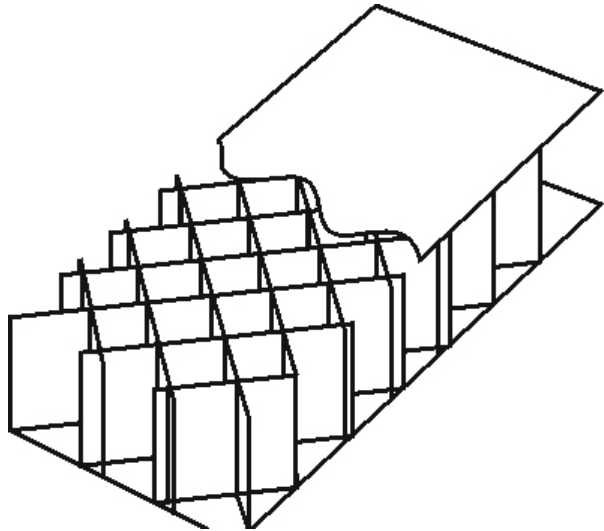
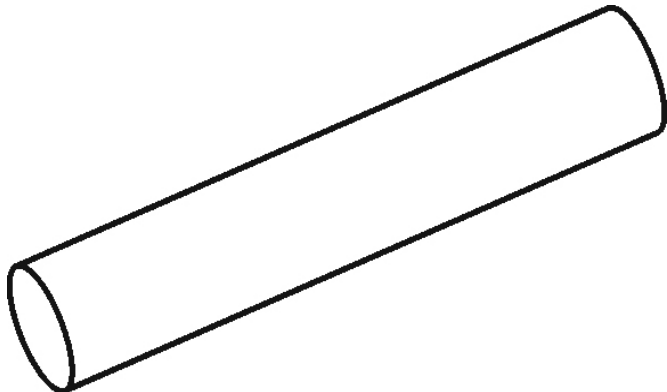

Cardboard Block (2-3" thick)

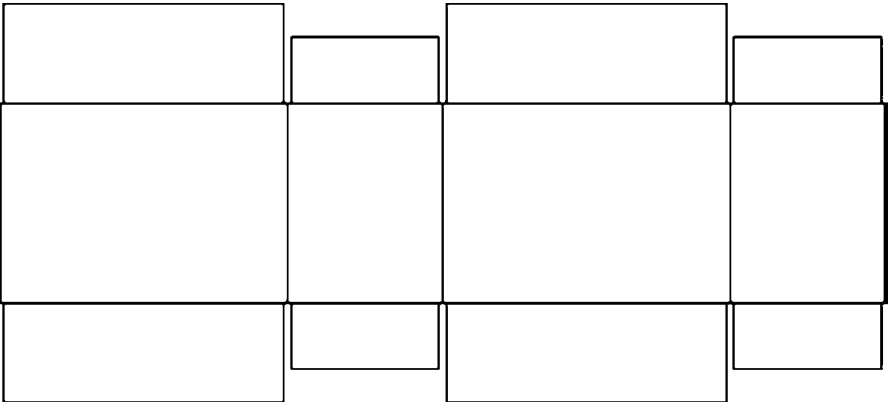

Cardboard Box - cut

# CARDBOARD BOAT DESIGN

- Consider the size of the boat - building & transporting
- Big enough to hold crew, small enough to transport and carry
- Wider is better for stability, but still must be able to paddle
- No surfboard style designs are allowed
- Rafts are allowed
- Consider total weight of all materials when wet
- EVERYTHING must be removed from the creek
- Boat decorations and crew costumes are encouraged - use your imagination; you will be awarded for your creativity!
- Set the Design Goal: Fun, Speed and Appearance
- Sketch out your design
  - build a scale model from manila paper:
    - estimate materials or plan how to use what you have
    - plan out what construction techniques will be used
- 1'x1'x3' box will float 187 lbs
  - if it will hold you, it's big enough to float
- Flat bottom, sit-to-paddle & canoe styles -are the best/easiest
- Rudders help keep you straight but make turning difficult and add complexity to your design
- Long boats go fast-but are harder to turn
- Short boats (<8') are difficult to keep straight
- Best length: 8-12 feet
- Best Height: 18 inches
  - Allows room to sit/kneel and still paddle over the edge
- Best Width:
  - 18"-30" (max) for 2 or more people front and rear
  - Minimum 48" for 2 people side by side
- Kneeling is a "power" position but sitting is more comfortable

# CARDBOARD BOAT PHYSICS

## “Wider is Better” - Center of Buoyancy

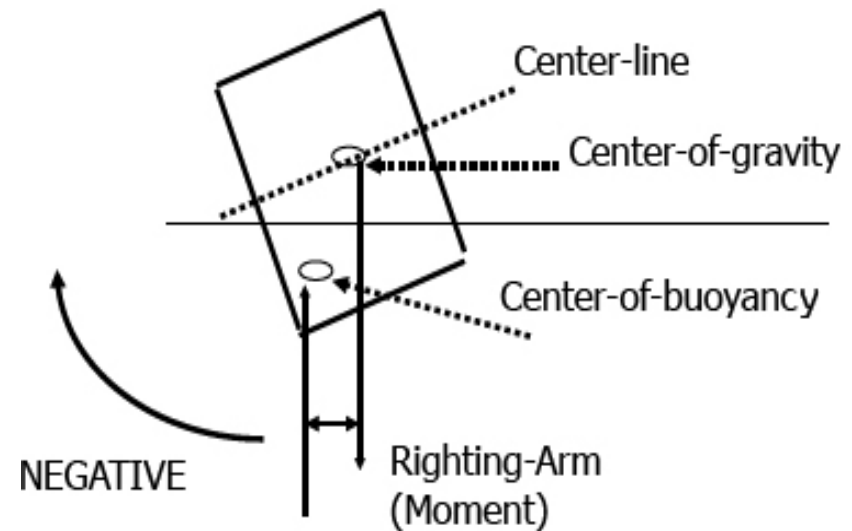
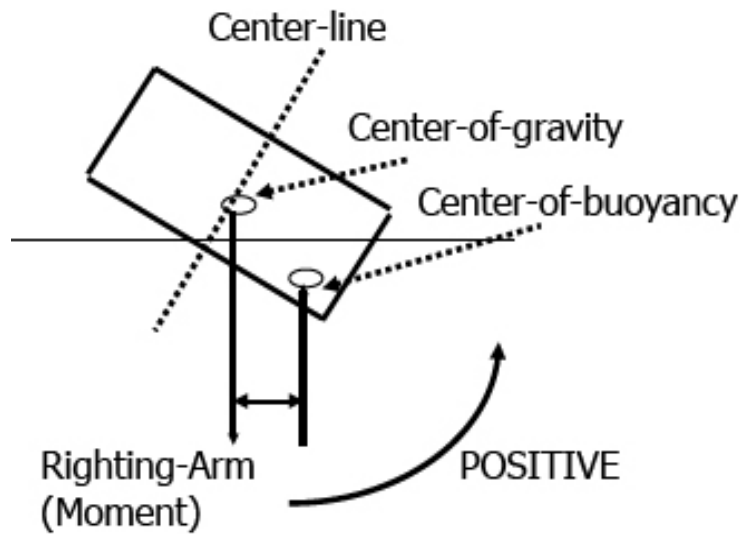

# Movement through the Water

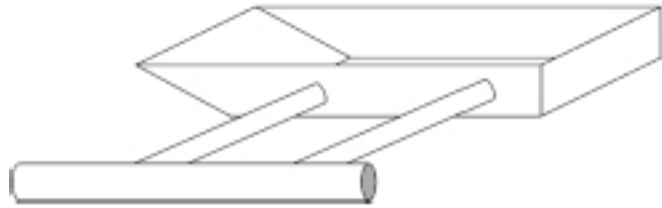

Outrigger  
Design



Pontoon  
Design



Raft  
Design

# CONSTRUCTION TIPS & TECHNIQUES

- Cover all edges of cardboard- acts like a siphon
- Cardboard tubes make great frames
  - Cut for joining and bending
  - Fasten tubes together
- Cardboard Hull
  - 1-2 layers, fasten and cover the seams
  - With 2 layers, overlap the seams and polyurethane in between
  - Decorate, paint, and varnish – this is your waterproofing so use a lot (paint will not stick to duct tape)
- Reinforce the area where you sit, kneel, or stand
- Carpenters glue and liquid nails work well (hot-melt glues melt in the heat and sun)
- Duct tape only non-painted surfaces (tubes or frame will be covered)
  - Duct tape shrinks when painted
  - Duct tape should be covered with masking tape if you need to paint it
  - Masking tape works well on glued edges and seams
  - Kraft paper with spray adhesive may also be used

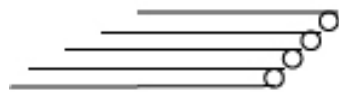

Solid Tube  
Frame

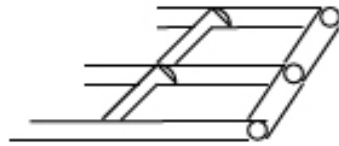

Center/Cross  
Beam  
Frame

### FRAMES

### CONNECTING TUBES

Cardboard  
Wrapper for Tubes  
End-to-End



Cardboard  
Wrapper for Tubes  
At Right-Angles

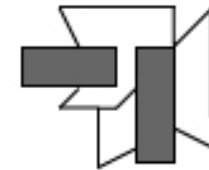

## FRAME ANGLES

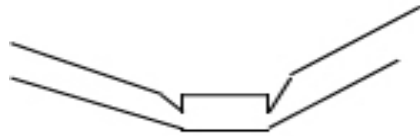

V-Shaped Cuts

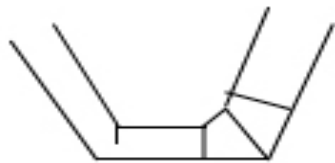

Multiple Cuts  
for Sharper Angles

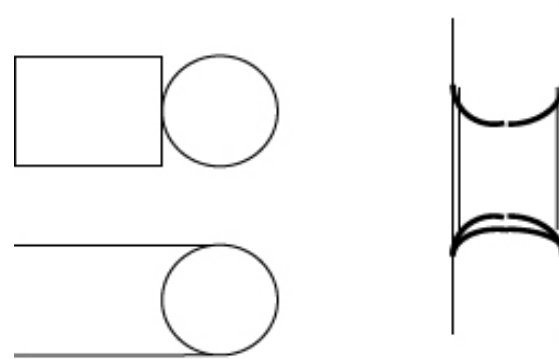

TUBE CUTTING  
TEMPLATE

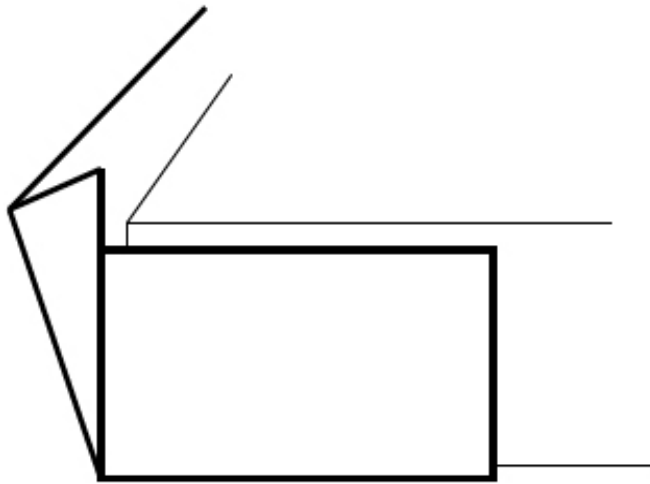

FOLD & OVERLAP  
CARDBOARD  
AROUND CORNERS

Crease/Score a line  
for a nice

STRAIGHT  
FOLD

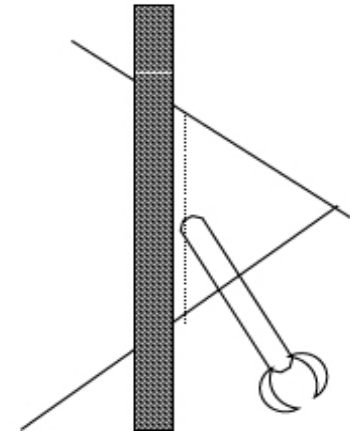



Multiple cardboard layers  
"glued" together on the sides  
*strengthen the hull*

Multiple trapezoid-shaped pieces  
"glued" together to form a  
*"support block"*

A sheet of cardboard  
could be folded &  
"glued" together to  
form *tubes/beams*

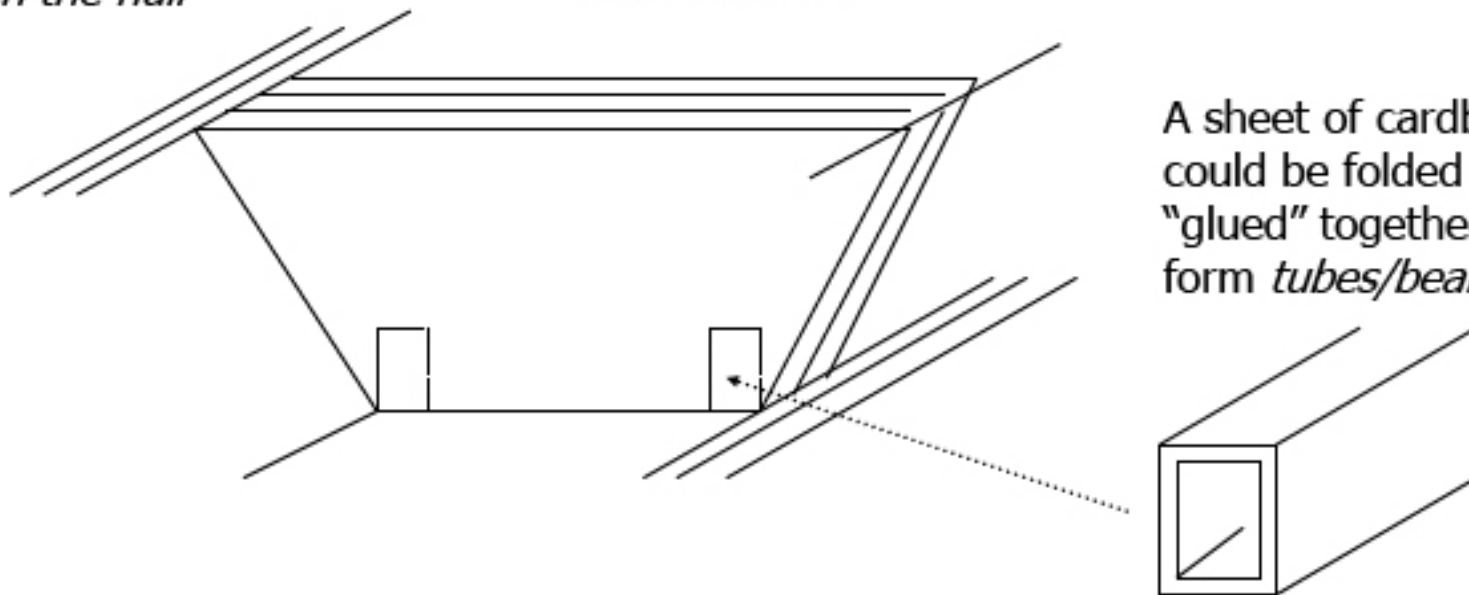

# WE WILL SEE YOU ON MACUM CREEK!

June 3<sup>rd</sup>, 2023





# WE WILL SEE YOU ON MACUM CREEK!

June 3<sup>rd</sup>, 2023

